

Northern Apparel Sourcing BD

Email: info@apparelsbd.com

Website: www.apparelsbd.com

COMPANY PROFILE



Md. R.A. Shohel, Chief Executive Officer

Email: sohel@apparelsbd.com



CONTENTS



ABOUT US	1-2
SERVICES	3
QUALITY ASSURANCE (Q.A.)	4
CORE SERVICES	5
PRODUCTION CAPABILITIES	6
MEN' S WEAR	7
WOMEN' S WEAR	8
OUTERWEAR	9
PRODUCTION	10
SOCIAL & ETHICAL COMPLIANCE	11
ABOUT BANGLAESH	12

INTRODUCTION

Greetings from Northern Apparel Sourcing BD!

your ultimate buying and sourcing destination!



We take this opportunity to introduce ourselves as a Buying and Sourcing Agent, Supplier & Inspection Company for Ready Made Garments product based in Dhaka, Bangladesh with an idea and concept to provide one-stop buying office service to our overseas buyers from Bangladesh!

Bangladesh has become a global top sourcing hub for all kinds of ready-made garment (rmg) from many years for foreign buyers/importers, retailers & chain stores in those developed countries since the production cost is very low here.

Northern Apparel Sourcing BD offers its prospective international buyers, the ultimate solution for sourcing excellent quality ready-made garments (rmg) product (Knit, Woven & Sweater) in all categories at competitive price range made with local/foreign fabrics and accessories as per buyers/customers choice/demand from Bangladesh.

We serve our customers by responsibly managing and committed to achieving the highest standards and meeting their needs through competitive pricing, quality, and reliable delivery.

Our enthusiasm remains as strong as when we first started on our road to success.

Make your dream true with us

ABOUT US

Our ultimate target is quality product and customer satisfaction!

Northern Apparel Sourcing BD. established in 2015, working as a buying house, sourcing agent, factory evaluator, quality controller and supplier based in Bangladesh. Our concept is to provide the overseas buyer quality product as required & specified, in time delivery with competitive price.

Our experience is broad and our understanding of existing fashion trends is profound. We have an experienced, pro-active and skilled work force to handle marketing, merchandising & production.

We deal in all kinds of Knit, Woven and Sweater Garments items e.g. denim & non-denim woven tops & Bottoms, T-shirt, Polo Shirt, Tank Top, Sweat shirt, Hoodies etc.

Our associated manufacturers' have fully compliance factories and most of them have vertical set-up, means they have in-house Knitting/dyeing/sewing & packing units. We value our relationship with our buyers and vendors as well, as our business practice!



Fig: Organogram

Make your dream true with us

ABOUT US

GENERAL INFORMATION:

NAME OF THE COMPANY

Northern Apparel Sourcing BD.

YEAR OF ESTABLISHMENT

In the year of 2015.

CONTACTS AND ADDRESS

WhatsApp: +88-01713-454351

Visit: www.apparelsbd.com

CONTACT PERSON

Email : info@apparelsbd.com

MODE OF PAYMENT

L/C at sight/T.T.

FINANCIAL INSTITUTIONS

Bank Name: One Bank Limited.

Account no.: CD 0181020007365

Customer ID.: 000547998

Branch Name.: Banani Branch

Address.: Abedin Tower

35, Kemal Ataturk Avenue, Banani C.A.

Dhaka-1213, Bangladesh.



EMPLOYEES AND STAFFS:

Merchandiser 05

Quality Controller 07

Research & Development 01

HR & Compliance 02

Commercial 01

Administration and Accounts 02

Product Development & Technician 02

Make your dream true with us

Customer's satisfaction is our commitment!

We started our journey of buying house & export, only to provide dedicated service to worldwide customers. We are committed to satisfy our customers and we relish the challenges that initially arise in a typically fast moving fashion world. We have professional merchandisers



and experienced QCs (Quality Controllers) team, having their adequate knowledge and expertise, understand the dynamics of apparel business that is fast paced and challenging.

Furthermore, we can assure, committed services to any buyer/importer/wholesaler/department chain stores around the world whose wish to do business with us.



Our services and activities:

- ☑ We quickly respond to our **BUYER'S ENQUIRIES** and **ORDERS** simultaneously.
- ☑ We **co-ordinates VISIT** to Bangladesh of foreign buyers.
- ☑ We arrange **VENDORS/ MANUFACTURING UNITS** depending on the customers' requirement.
- ☑ We arrange **FACTORY INSPECTION** by the buyer.
- ☑ We **SOURCES** raw materials, accessories, care labels, printings and fabric from import /local.
- ☑ We monitoring **PRODUCTION and QC** inspection.
- ☑ We **update**of **PRODUCTION** to our buyers on a regular basis.
- ☑ We ensure on time **DELIVERY/ SHIPMENT**.
- ☑ We **CARE** about the new buyer same that we do for our other buyers.

Northern Apparel Sourcing BD welcomes all prospective buyers to visit and evaluate our Service.

QUALITY ASSURANCE (Q.A.)

Quality Assurance is key tasks for the part of a supplier and manufacturer as well. Manufacturers has to source materials from different places, garments is being stitch by different skilled workers.

Therefore, it has to be ensured that produced garments quality is as per buyer's requirements. For that we follow:

1. Quality Policy:

Quality Policy is being maintained and updates it to the respective buyers for optimum quality assurance (Q.A.) of product as per buyer's requirements.



3. Quality Team:

In order to maintain product quality assurance, we have skilled quality assurance team.



2. Quality Control Circles:

Quality Control Circle adopted in production cycle, dedicatedly for solving workplace problem.

4. Quality Checking and Maintenance:

Total goods are checked before shipment for quality assurance. Yarns are lab-tested for pilling resistance, color fastness etc. All kinds of raw materials are preserved in warehouses in a professional manner. All production floors keep clean and maintain all necessary safety measures according to compliance.



CORE SERVICES

Northern Apparel Sourcing BD plays important role in regard to the quality, quantity, fashion and price.

Cost Effective:

We provide the buyer a product with competitive price and best quality, it'll help to catch the mass level consumer market without single dollar investment.

Quality Concern:

We always take care of the product's quality as per buyer specifications to prevent buyer's losses for reputation as well as money. We perform all kind of services with buyer' and suppliers'full satisfaction.

Lead-Time:

The supplier normally achieved 90 -120 days for a single order execution lead time. In the recent year, it's reducing significantly, but not more than 60 days that mean within this anything can happen. We provide support in this complex supply chain process; it is badly needed in the supplier side especially in the production time for smooth production, so that quality and production both will be maintained in stipulated time.

Communication:



We make sure that there is no communication gap between both buyer and supplier, and order is being executed as per actual requirement. We have professional and technical know-how team about the subject, who receive product information from buyer and communicates to the manufacture, make understand to their own language for proper execution of the order.

Product Development:

New design development is very important for every retailer. So, we help to develop number of new products, by provide quick support from the supplier.

Market Analysis:

We updates market information of Manufacturing country's in regard to political situation, labor law, review of the worker salaries, yarn price, accessories price, fabric price, lead-time, the future of the business, FDI (foreign direct investment) and many other issues related to production, which help a fast growing buyer in future budget and production planning.

PRODUCTION

A monthly capacity of 1 million pieces across all factories.

Factory Setup: We have number of factories working under our umbrella starting from 300 machines to 6000 machines.

Our all factories are full compliance and most of Knit factory have vertical set-up means they have in-house Knitting/dyeing /garment sewing & packing.

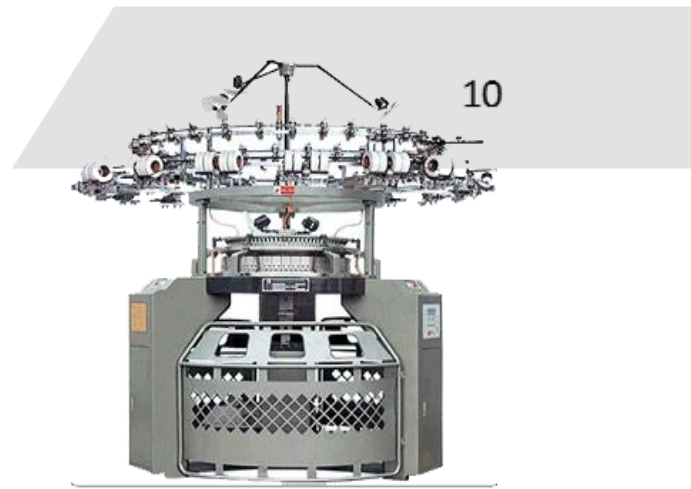

Knitting



Sewing



Dyeing



Make your dream true with us

SOCIAL & ETHICAL COMPLIANCE



We ensure ethical practices that are maintained as per international laws, related to child labor, forced labor, health and safety, working hours & compensation etc.

- Minimize the local export law complicity: We help and make sure buyer know details about business laws, rules-regulations, LC term & condition, licenses information etc required to do business in Bangladesh.

- Risk minimization: We responsibly manage the environmental, social and governance performance. We work with their customers, suppliers and industry partners to further the sustainability of supply chains and communities across the network.



PRODUCTION CAPABILITIES

- ➔ Jersey tee-shirts
- ➔ Polo-shirts,
- ➔ Dresses and Skirts
- ➔ Shirts and Blouses
- ➔ Denim Casual Trousers
- ➔ Jackets
- ➔ Shorts
- ➔ Underwear
- ➔ Nightwear
- ➔ Outerwear
- ➔ Sweaters



NORT
Apparel Sourcing BD



Make your dream true with us

MEN'S WEAR



Make your dream true with us

WOMEN'S WEAR



Make your dream true with us

OUTERWEAR



ORTA
parel s
RD



Make your dream true with us

ABOUT BANGLADESH

Bangladesh, a land of exhilarating mix with fascinating history, vibrant cultures, panoramic beauties, historical ruins, flora and fauna, hills and forests, sandy sea beaches and wildlife, is waiting to welcome you to visit Bangladesh. You will easily be impressed with so much variety of attractiveness within such a small geographic boundary; The world's longest sandy beach-Cox'sbazaar, the world's single largest

mangrove forest- Sundarbans, Oceanic Kuakata, Coral island-Saint martin's, the green roof of the country-Bandarban, a land of colorful Indigenous groups and Lake City-Rangamati, the scenic beauty of the hilly regions, historic and archaeological sites etc. are of life time experience for travelers. Bangladesh is a land of tourists, researchers, and wildlife and nature lovers. During visit Bangladesh you will come across the rich cultural heritages and history of Bangladesh.

SUNDARBAN

World's largest mangroveforest UNESCO- WORLD HERITAGE



COX'S BAZAAR

World's longest sea beach



CRECKETEAM

Bangladesh CRICKET PLAYING NATION





COMPANY PROFILE



 **NORTHERN**
Apparel Sourcing BD

Contact Us

 "Shopnil Shade"- House # 07, Road # 01, Block # B, Pallabi, Mirpur # 12,
Dhaka-1216, Bangladesh.

 Mobile No: +88-01713-454351, +88-01911-322041, WhatsApp: +88-01713-454351

 Email Address: sohel@apparelsbd.com, info@apparelsbd.com

 Website: www.apparelsbd.com



Make your dream true with us